

PC SERIES - LP15

Personnel Carrier Vehicle

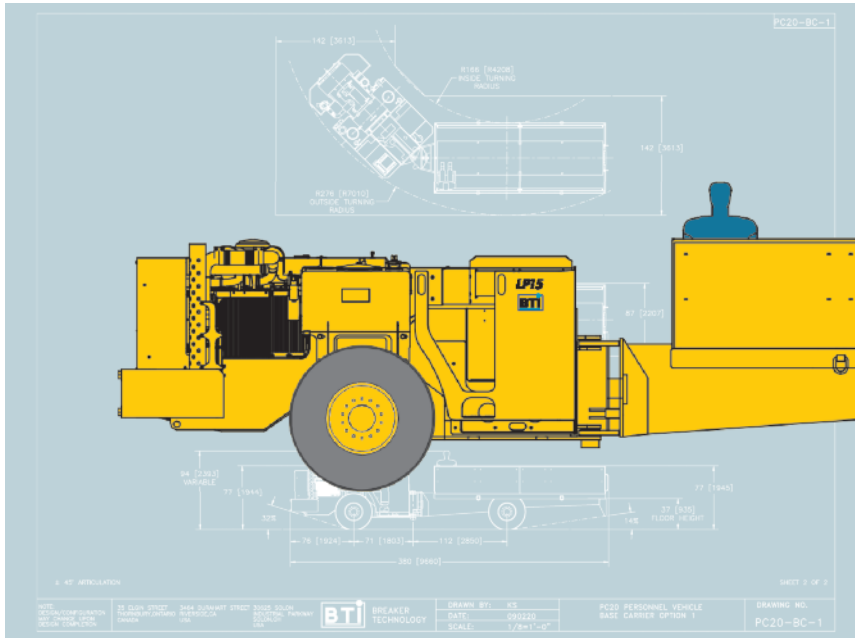

AT A GLANCE

Weights & Dimensions:

Operating Weight 32,000 lbs (14,545 kg)	Overall Traming Length 31'-8" (9.7m)	Overall Width 7'-3" (2.21m)
Traming Height 7'-10" (2.38m)-variable	Carrier Articulation +/- 45°	Inside Turning Radius 13'-10" (4.21m)
Outside Turning Radius 23'-0" (7.01m)		

Note: weights & dimensions are nominal and vary depending on final engine, operator's enclosure & option configuration.

Engine Configurations:

- Deutz BF4M1013C 122HP @ 2300 rpm MSHA/Tier II
- ▲ Caterpillar C4.4 ACERT 127HP @ 2200 rpm Tier III

● Standard ▲ Optional

Personnel Capacity

20 + Operator, + Optional Passenger seat

Bench Seating with Backrests

Three Point Access into Rear Passenger Area

Rear Deck Area

7'-3" x 17'-4" (2.2m x 5.3m)

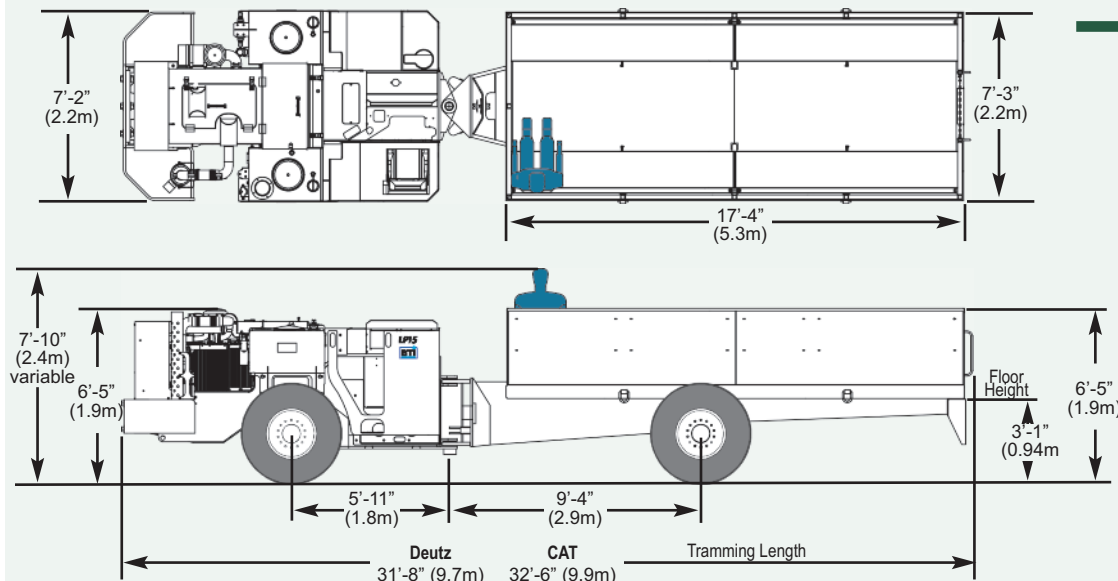

OPTIONS

- Protective operator structure
- Seating configurations
- Air intake system
- Personnel canopy, plexiglass windows and interior lighting
- Personnel seating
- Exhaust system
- Fuel filling system
- Hydraulic filling system
- Tires
- Fire suppression system
- Wheel chocks

PC SERIES (LP15) PERSONNEL CARRIER COMPONENTS

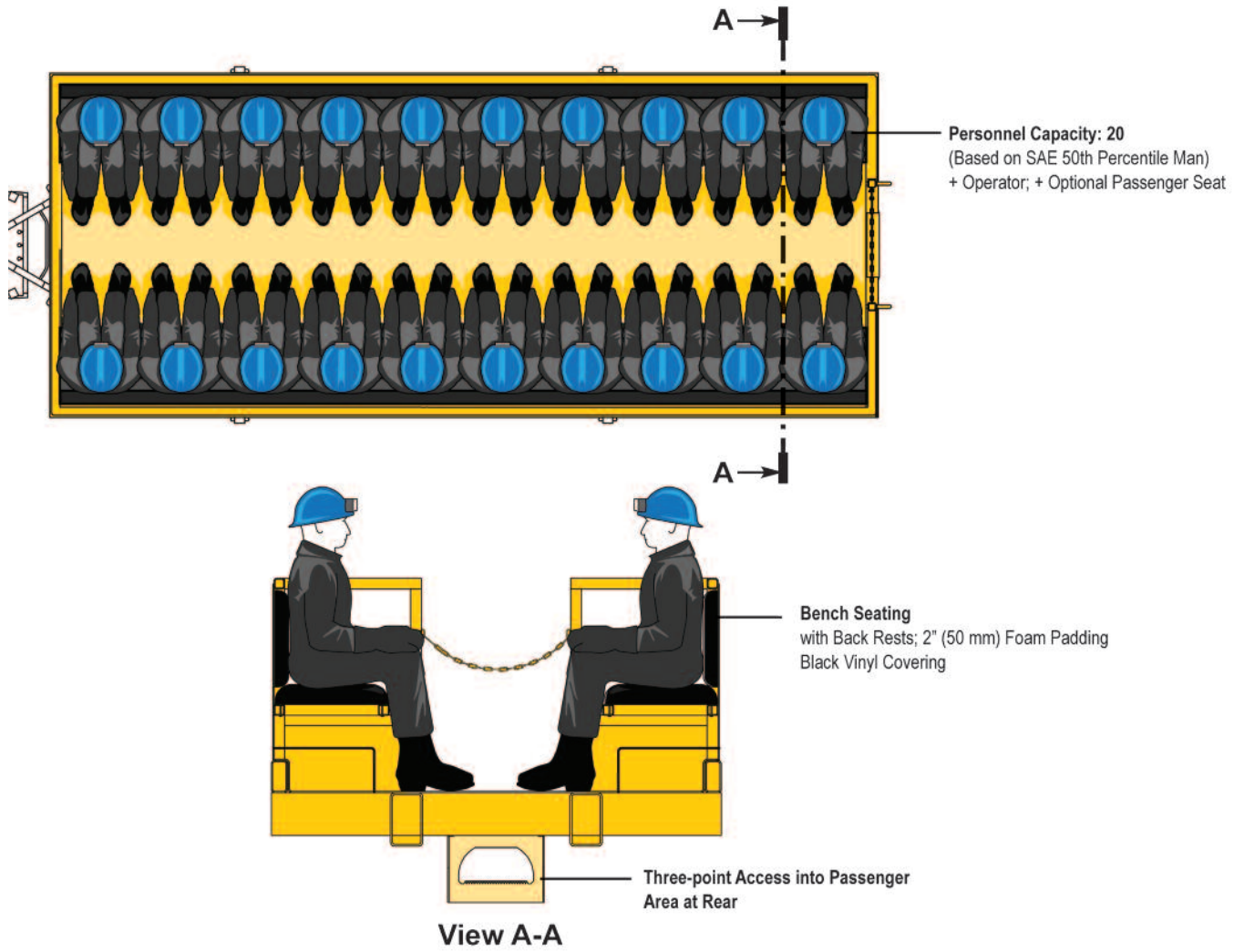

DRIVING SPECIFICATIONS

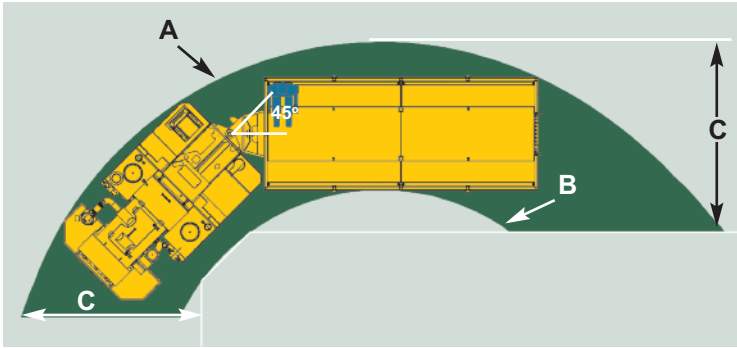

Turning Radius

Turning radius: +/- 45° articulation

		Deutz	Caterpillar
A	Outside Turning Radius	23'-0" (7.01m)	23'-2" (7.07m)
B	Inside Turning Radius	13'-10" (4.21m)	
C	Minimum Mine Tunnel Width	11'-10" (3.61m)	12'-0" (3.67m)

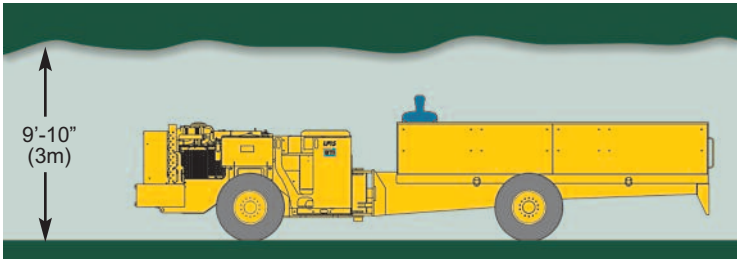

Recommended Drift Height

BTI recommends a minimum drift height with cab:
9'-10" (3m)

LP15 CARRIER - COMMON FEATURES

- Standard - common to all engine combinations
- ▲ Optional

Notes: _____

- **CHASSIS**
LP15 articulated 4-wheel drive, all welded construction
- **ENGINE END OSCILLATION**
+/- 8° c/w heavy framed external walking beam
- **CARRIER ARTICULATION**
+/- 45° by two opposing 4" (100mm) bore x 2" (50mm) rod steering cylinders complete with stick steering control
- **HYDRAULIC CIRCUIT**
50 gallon (189 liter) hydraulic tank
Hydraulic piston pump with load sense control
In-line hydraulic pressure filter / In-line return filter
- **ELECTRICAL CIRCUIT**
24 VDC start/run 100 amp alternator
Murphy Power Vu instrument cluster for electronic engines
Two LED red tram marker lights & two 70 watt halogen head lights on engine end
Two LED red tram marker lights & two 70 watt halogen head lights on deck end
- **PERSONNEL CAPACITY**
Personnel capacity of 20 based on SAE 50th percentile man
+ Operator, + Optional Passenger Seat
- **LADDER ACCESS**
Three point ladder access at rear

PC (LP15) PERSONNEL VEHICLE CONFIGURATIONS

Choose one per group

- Standard
- ▲ Optional

Notes: _____

POWERTRAIN GROUPS

- Deutz BF4M1013C
- ▲ Caterpillar C4.4 ACERT

PROTECTIVE STRUCTURE

- Dual compartments for operator and passenger, no protective enclosure
- ▲ ROPS/FOPS certified canopy - open air
- ▲ ROPS/FOPS certified fully enclosed cab full width. Engine belt driven HVAC heat/air conditioner for engine driven applications

OPERATOR SEAT

- Suspension Seat, fixed
- ▲ Air Ride Seat, fixed

PASSENGER SEAT

- No passenger seat
- ▲ Suspension Seat, fixed
- ▲ Air Ride Seat, fixed

PERSONNEL CANOPY

- No personnel canopy
- ▲ Bolt-on personnel canopy - tubular construction - for personnel overhead protection

WINDOWS

- No windows - open air
- ▲ Personnel canopy fitted with shock absorbing plexiglass windows to protect personnel from elements outside the carrying area (only available with canopy option)

FOLDABLE BENCH SEATING

- Fixed personnel bench seating
- ▲ Foldable bench seating in personnel section, allowing extra cargo space when not transporting personnel

INTERIOR LIGHTING

- No interior lighting
- ▲ Qty of 2 - 24 volt 70 watt halogen lamp interior lights for personnel carrying area (only available with canopy option)

AIR INTAKE SYSTEM

- Air Intake Filter
- ▲ Air Intake Precleaner

EXHAUST SYSTEM

- Catalytic exhaust
- ▲ Exhaust Manifold and Turbo Coating
- ▲ Exhaust System Wrap

FUEL SYSTEM

- Fuel Tank - 50 gallon (189 liter)
- ▲ Fuel Tank with Fast Fill - 50 gallon (189 liter)

FL (LP15) CARRIER CONFIGURATIONS

Choose one per group

- Standard ▲ Optional

Notes: _____

HYDRAULIC TANK

- Hydraulic Tank - 50 gallon (189 liter)
- ▲ Hydraulic Tank with Fast Fill - 50 gallon (189 liter)

TIRES

- Pneumatic 12:00 x 20; 20 ply mine lug
- ▲ Solid: 12:00 x 20
- ▲ Foam Filled: 12:00 x 20
- ▲ Solid: 10:00 x 20

FIRE SUPPRESSION SYSTEM

- No fire suppression
- ▲ Fire Extinguisher, 1 x 20 lb (9kg)
- ▲ Ansul Fire Suppression System
- ▲ Ansul Fire Suppression with Auto Detection

WHEEL CHOCKS

- No wheel chocks
- ▲ Aluminum Wheel Chocks

POWERTRAIN GROUP OPTIONS

- Standard
- ▲ Optional

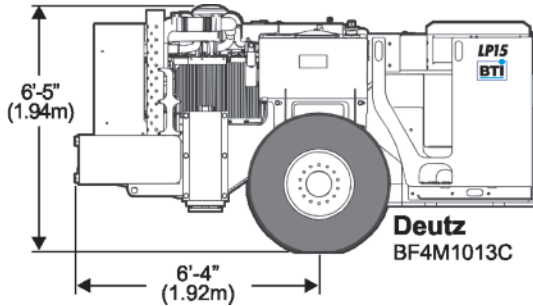

- **Engine:** Deutz BF4M1013C, four cylinder, turbocharged, intercooled Diesel, MSHA, Tier II, 122 HP @ 2300 RPM c/w fuel filter and water separator

Torque Converter: Clark C2000 series

Transmission: Clark 20,000 series, long drop, remote mounted, electric shift
Three forward and three reverse speeds

Vehicle speeds with 12:00.x 20 tires @ 2200 rpm with standard axle ratio:
1st gear: 2.4mph (3.9kph) - 2nd gear: 6.2mph (10.9 kph) - 3rd gear: 11.4mph (18.3 kph)

Engine end axle: New Holland D65I no spin differential wet disk SAHR emergency brakes, wet disk HASR service brakes, complete with external walking beam, +/- 8 degrees oscillation

Boom end axle: New Holland D65I no spin differential wet disk SAHR emergency brakes, wet disk HASR service brakes

Drivelines: Mechanics 6C and 7C

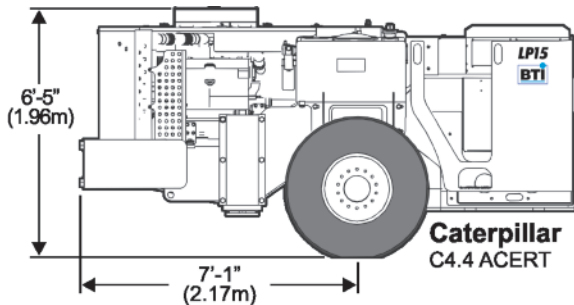

- ▲ **Engine:** Caterpillar C4.4 ACERT electronic four cylinder, turbocharged, intercooled Diesel, Tier III, 127 HP @ 2200 RPM c/w fuel filter and water separator.

Torque Converter: Clark C2000 series

Transmission: Clark 20,000 series, long drop, remote mounted, electric shift
Three forward and three reverse speeds

Vehicle speeds with 12:00.x 20 tires @ 2200 rpm with standard axle ratio:
1st gear: 2.4mph (3.9kph) - 2nd gear: 6.2mph (10.9 kph) - 3rd gear: 11.4mph (18.3 kph)

Engine end axle: New Holland D65I no spin differential wet disk SAHR emergency brakes, wet disk HASR service brakes, complete with external walking beam, +/- 8 degrees oscillation

Boom end axle: New Holland D65I no spin differential wet disk SAHR emergency brakes, wet disk HASR service brakes

Drivelines: Mechanics 6C and 7C

PROTECTIVE STRUCTURES OPTIONS

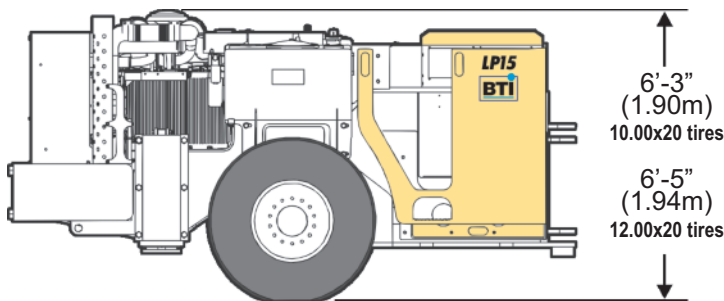

- **Standard Operator Compartment**

Standard dual compartments for operator and passenger.

PROTECTIVE STRUCTURES OPTIONS

● Standard ▲ Optional

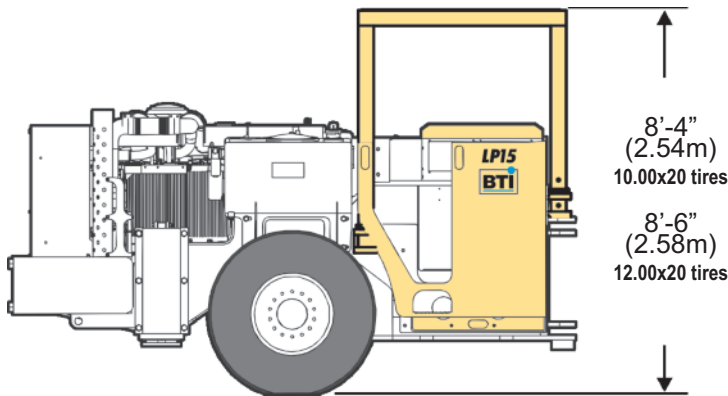

▲ ROPS/FOPS Canopy

ROPS/FOPS certified 100" configuration, open air.

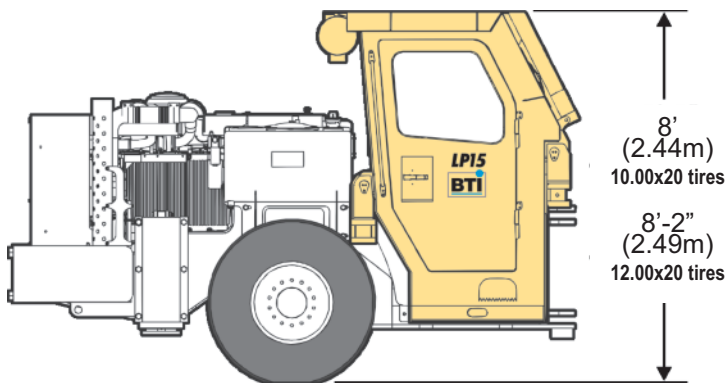

▲ ROPS/FOPS Cab

Full cab; covers operator, controls and passenger. Tested and certified ROPS/FOPS cab, complete with guard bars to help protect operator and passenger from dangerous fly-rock. Includes heavy-duty safety glass, wiper/washers, HVAC heat / air conditioning system, air pressurization system.

OPERATOR SEAT OPTIONS

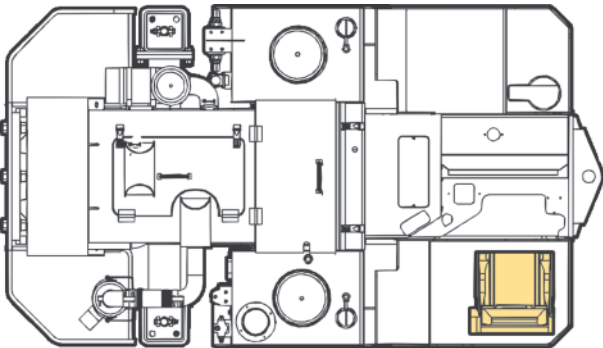

Operator Seat Options

● Suspension Seat, fixed ▲ Air Ride Seat, fixed

Mine duty operator seat options available in fixed suspension and fixed air ride variations.

PASSENGER SEAT OPTIONS

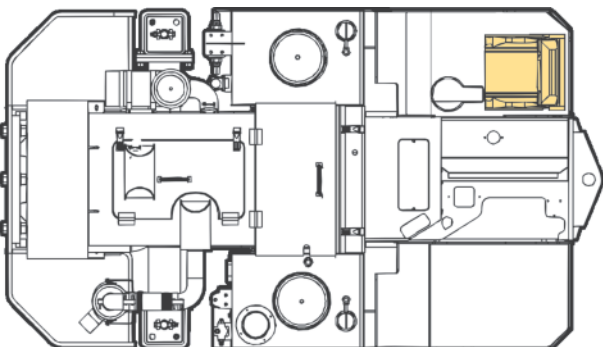

● No Passenger Seat

Passenger Seat Options

▲ Suspension Seat, fixed (facing front) ▲ Air Ride Seat, fixed (facing front)

Mine duty passenger seat options available in fixed suspension and fixed air ride variations.

AIR INTAKE SYSTEM OPTIONS

● Standard ▲ Optional

● Air Intake Filter

A dry element filter with safety element and replacement indicator.

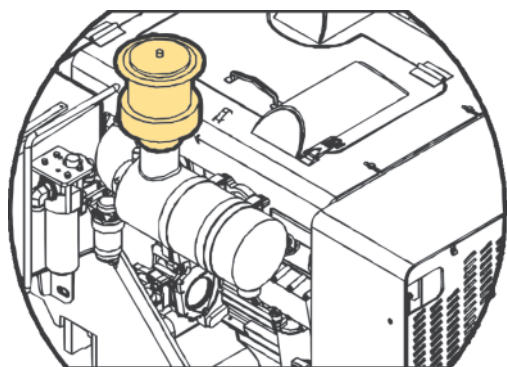

▲ Air Intake Precleaner

A dry element filter with safety element and replacement indicator, complete with a cyclone Pre-cleaner.

A pre-cleaner extends the life of your air filter by removing dirt and contaminants before they reach the filter and ejecting them automatically via the exhaust.

EXHAUST SYSTEM OPTIONS

● Catalytic Exhaust

A catalytic exhaust, purifier/silencer. No exhaust blanket.

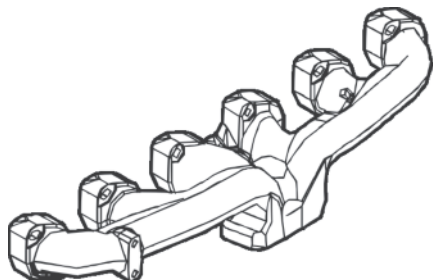

▲ Exhaust Manifold and Turbo Coating

Prevents fluids from igniting on hot engine and exhaust parts. High temperature performance: ideal for engine compartment components requiring long-term exposure to high temperatures.

Non-flammable. Protects personnel from burns.

Lowers ambient temperature; cooler engine compartment, less heat stress on operators and maintenance personnel.

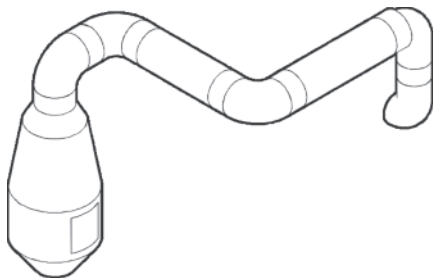

▲ Exhaust System Wrap

Prevents fluids from igniting on exhaust parts. High temperature performance.

Non-flammable. Protects personnel from burns.

Lowers ambient temperature; cooler engine compartment, less heat stress on operators and maintenance personnel.

FUEL TANK OPTIONS

● Fuel Tank

50 gallon (189 liter) fuel tank, top fill.

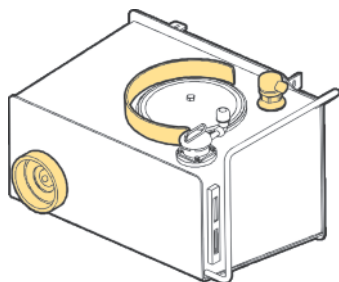

▲ Fuel Tank with Fast Fill

50 gallon (189 liter) fuel tank complete with fast filling system. Designed for on-site fast fluid transfer.

HYDRAULIC TANK OPTIONS

- Standard ▲ Optional

● Hydraulic Tank

50 gallon (189 liter) hydraulic tank, top fill, 4 psi pressurized cap.

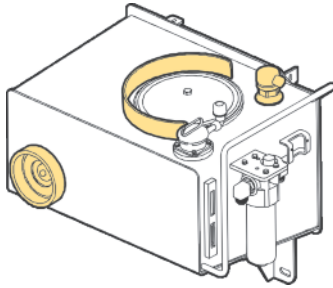

▲ Hydraulic Tank with Fast Fill

50 gallon (189 liter) hydraulic tank complete with fast filling system. Designed for on-site fast fluid transfer.

TIRE OPTIONS

● Pneumatic Tires

12:00 x 20; 20 ply mine lug pneumatic tires

▲ Solid Tires

12:00 x 20 solid tires

▲ Foam Filled Tires

12:00 x 20 foam filled tires

▲ Solid Tires

10:00 x 20 solid tires

FIRE SUPPRESSION SYSTEM OPTIONS

● No Fire Suppression System

▲ Fire Extinguisher

1 x 20 lb (9 kg) fire extinguisher.

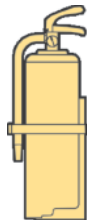

▲ Ansul Fire Suppression

Ansul fire suppression system, 6 nozzle, complete with 2 actuators. Complete with 20lb (9 kg) fire extinguisher.

▲ Ansul Fire Suppression with Detection

Ansul fire suppression system, 6 nozzle, complete with 2 actuators. Includes a check fire detection and activation system. Complete with 20lb (9 kg) fire extinguisher.

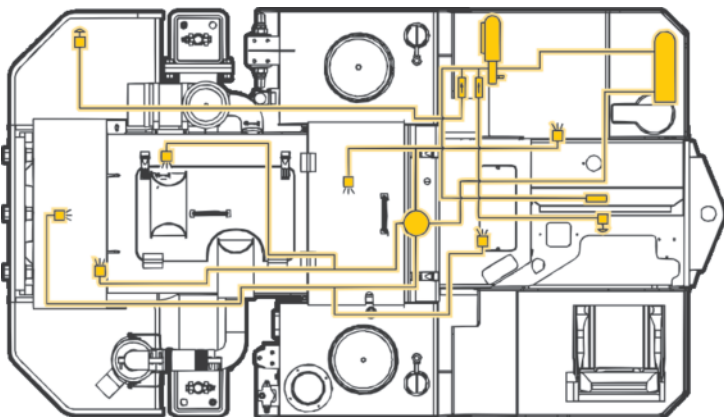

WHEEL CHOCK OPTIONS

- Standard
- ▲ Optional



● No Wheel Chocks

▲ Wheel Chocks - aluminum

complete with holder

PERSONNEL CANOPY OPTIONS

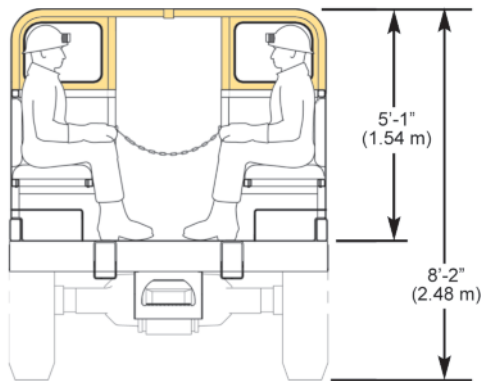

● No Personnel Canopy

▲ Personnel Canopy

Bolt-on personnel canopy - tubular construction - for personnel overhead protection

WINDOW OPTIONS

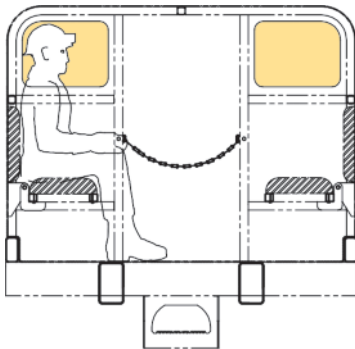

● No Windows - open air

▲ Windows

Personnel canopy fitted with shock absorbing plexiglass windows (only available with canopy option)

FOLDABLE SEATING OPTIONS

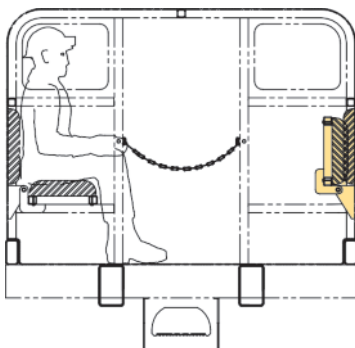

● Fixed Bench Seating

▲ Foldable Bench Seating

Allows for extra cargo space, when not transporting personnel.

INTERIOR LIGHTING OPTIONS

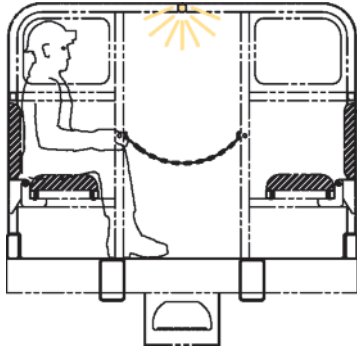

● No Interior Lighting

▲ Qty of 2 - 70 watt interior lights

Interior lighting for personnel carrying area
Halogen lamp 24 volt 70 watt
(only available with canopy option)



10350-ENG-0609

All dimensions and specifications are subject to change without notice.

BREAKER TECHNOLOGY an Astec Industries Company

UNITED STATES EAST 440.248.7168 • UNITED STATES WEST 951.369.0878 • CANADA/INTERNATIONAL 519.599.2015 • rockbreaker.com

